



# 6235-C/6235A-C

## SOFT SERVE FREEZER

Two Flavor, Countertop, Digital Control  
A: Pump Feed Model

### Powerful and Versatile

Two flavor medium capacity countertop model for ice cream, frozen yogurt and much more

#### Fast Freeze Down

Patented high efficiency heat exchanger allows fast freeze down with low energy consumption

#### Digital Control and Display

Microprocessor control provides access to system settings and additional functions. Digital interface displays critical info as system status, temperatures, dispense count, errors, etc.

#### Auto Programming

Allows automatic switching of operation modes based on preset schedules

#### Standby

Maintains product temperature in both mix hopper and freezing cylinder below 4.4°C (40°F) overnight

#### Hopper Agitator

Maintains product consistency, prevents product separation

Ideal for medium capacity outlets to serve ice cream, frozen yogurt, gelato or sorbet. Fully loaded with all standard options.



#### Soft System Start

Slow motor start reduces equipment noise and stress on drive train

#### Direct Drive Transmission

Eliminates consumable moving parts and increases transmission efficiency

#### Defrost for Cleaning

Increases efficiency during cleaning by heating frozen product in cylinder

#### Quick Freeze

Turn on freeze immediately to freeze down to serving viscosity when quick service is required after long idle period

#### Self-closing Valve with Speed Control

Automatically prevents product overflow after dispense; Provides flexibility in dispense rate control

#### Safety Protections

- Low temperature and motor overload shutoffs to protect in the event of cylinder freeze up
- High pressure switch to prevent compressor overheating



# 6235-C/6235A-C

# SOFT SERVE FREEZER

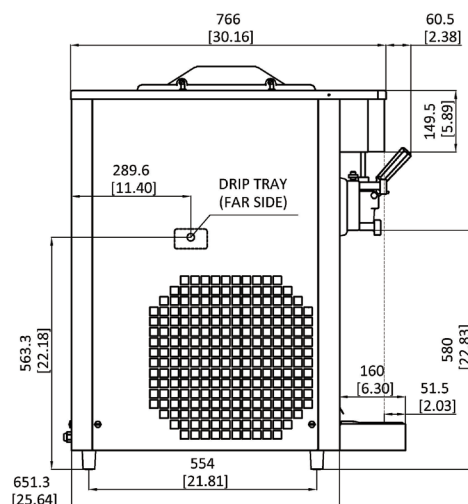
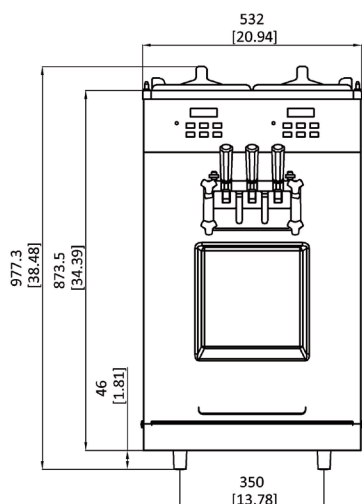

## SPECIFICATIONS

Flavors	2 + Twist
Freezing Cylinders	2 x 1.7 L / 1.8 qt
Mix Hoppers	2 x 12 L (8 L for A)
Output Capacity (80 g)	450 serves/hr
Clearance Requirements	152 mm/6" on left

Weight	Kg/lb (Gravity)	Kg/lb (Pump)
Net	173 / 381	188 / 414
Shipping	187 / 412	202 / 445

Dimensions	Net (mm/in)	Shipping (mm/in)
Width	532 / 20.9	610 / 24.0
Depth	651 / 25.6	860 / 33.9
Height	977 / 38.5	1120 / 44.1
Volume	0.59 CBM / 20.75 CBF	

Electrical	Power (kW)	Total Amps (A)	Fuse (A)
220-240/50/1	3.3	17	20
208-230/60/1	3.6	16	20

## FEATURES

Control Systems	Two, Digital
Refrigerated Hoppers	✓
Hopper Agitators	✓
Temperature Displays	✓
Standby Mode	✓
Auto Closing Dispensing Valves	✓
Dispensing Speed Control	✓
Low Mix Indicator Light & Alarm	✓
Low Temperature Protection	✓
Motor Overload Protection	✓
High Pressure Protection	✓
Defrost & Quick Freeze	✓
Soft Start	✓
Direct Drive Pump (A only)	✓

## AVAILABLE OPTIONS

Water Cooled	✓
Top Air Discharge Chute	✓

• Above specifications are subject to change without notice